

Two cylinder, four cycle smoothness in a lightweight, compact engine

A new generation of marine diesel engines

The new Westerbeke B advanced series engines have the smallest "envelope" available ("envelope" is the combined length, width, height). These lightweight low profile engines are designed to fit into the smallest of engine compartments. They are engineered by Westerbeke, pioneers in marine diesel engines, to provide consistent performance, quietness, durability and above all reliability, year after year.

The new B series engines are easy to install, economical to operate, and convenient to service. A full range of options is available allowing you to custom tailor your engine to fit your individual requirements.

Parts and service are available worldwide. Westerbeke engines and generators can be serviced by over 600 authorized dealers strategically located in major navigable waterways in the United States and Canada, as well as in 20 countries overseas.

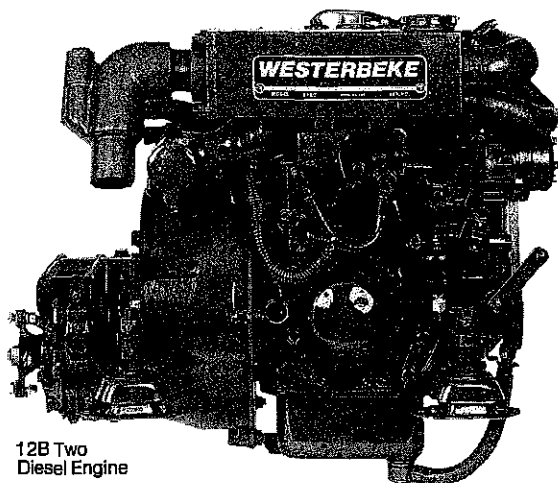

12B Two
Diesel Engine

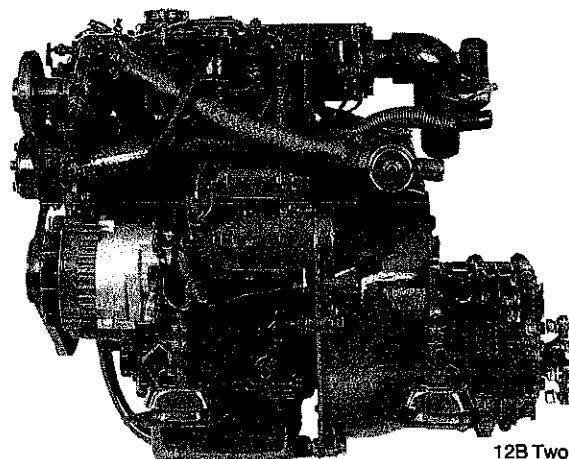

12B Two
Diesel Engine

Many features are standard equipment

- Fresh water cooling
- Engine prewired to plug-in connector
- Self-bleeding fuel system
- 12 volt 35 ampere alternator
- Flow control domestic hot water connections
- Coolant recovery tank
- Throttle, stop, and shift control brackets
- Low oil pressure and high water temperature alarms
- Glow plug cold starting aid
- Four point adjustable flex mounts
- Lube oil drain hose
- Flexible fuel supply and return connector
- Operator's Manual and Parts List

Performance Data

Horsepower and rpm
12 hp @ 3600 rpm

Maximum torque and rpm
19 lbs/ft @ 2700 rpm

Typical fuel consumption
0.006 US gal/hp/hr
(0.227 liters/hp/hr)

Typical fuel consumption
@ 2500 rpm
0.3 US gal/hr
(1.14 liters/hr)

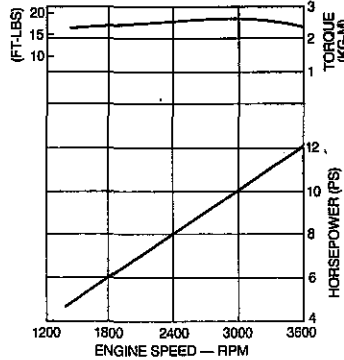

Specifications

Number of cylinders	2 Cylinder vertical in-line
Cycles	4 Cycle
Displacement	27.52 cu. in. (4.5 liter)
Bore and stroke	2.56" x 2.68" (65 mm x 68 mm)
Compression ratio	25:1
Maximum angle of installation	Not to exceed 14°
Maximum angle of operation	Not to exceed 25°
Crankshaft, direction of rotation	Counterclockwise as viewed from flywheel end
Propeller shaft, direction of rotation	Right hand → std. trans.
Dry weight	205 lbs (92.9 kilos)
Combustion system	Swirl type
Aspiration	Naturally aspirated
Lubrication system	Forced lubrication by gear pump
Cooling system	4.0 quarts (3.78 liters)
Starting aid	12 volt sheathed type glow plug
Engine stop	Manual type
Fuel injection pump	Bosch type
Governor	Centrifugal type
Injectors	Throttle type
Fuel filter	Primary & secondary
Lube oil filter	Full flow, spin-on element
Lubricant capacity	2 quarts (1.89 liters)
Fuel transfer pump	Electrical plunger type
Fuel supply and return piping	1/4" ID (.635 mm) minimum 3/8" ID (.952 mm) maximum
Starting motor	12 volt, solenoid, actuated shift
Battery charging alternator	35 ampere (12 volts)
Cold cranking amps	209 amps
Alternator/regulator	Automatic, solid state built-in
Electrical system	12 volts DC, negative ground

Construction — Engine Components

Cylinder head	Cast iron
Cylinder block	Cast iron
Crankshaft	Forged crankshaft, three main bearings
Valves	Overhead valves, rotating type
Fuel system	Self bleeding
Intake system	Tuned intake silencer for maximum noise reduction
Cooling system	Fresh water cooled with tube and shell type heat exchanger
Exhaust manifold	Cast aluminum, fresh water-cooled with built-in expansion tank

Standard Equipment

Standard gear ratio	2.05:1
Mounting centers	15"
Flexible mounts	Adjustable full safe rubber type
Flow control domestic hot water connection	
Coolant recovery tank	
Battery charging alternator	
Starting aid	
Control brackets	For all control attachments
Prewired Engine	
Belt-driven sea water pump	
Lube oil drain hose	
Oil fill	Top
Flexible fuel supply and return connection	
Operator's Manual	
Parts List	

Optional Equipment

Captain panel with alarm (tachometer with lights)	
Admiral panel with alarms (tachometer with gauges)	
Dual station senders	
Other gear ratios	Consult local Distributor
Remote expansion tank	
Fuel/water separator	
Muffler and fittings	
"A" on board spare parts kit	
"B" extended cruising spare parts kit	
Anti-siphon valve for overboard cooling discharge water	
Technical Manual	
Exhaust connection (water injected 90°/45° elbows & riser)	
Propeller shaft couplings (rigid/flexible) — available standard sizes	

Dimensions

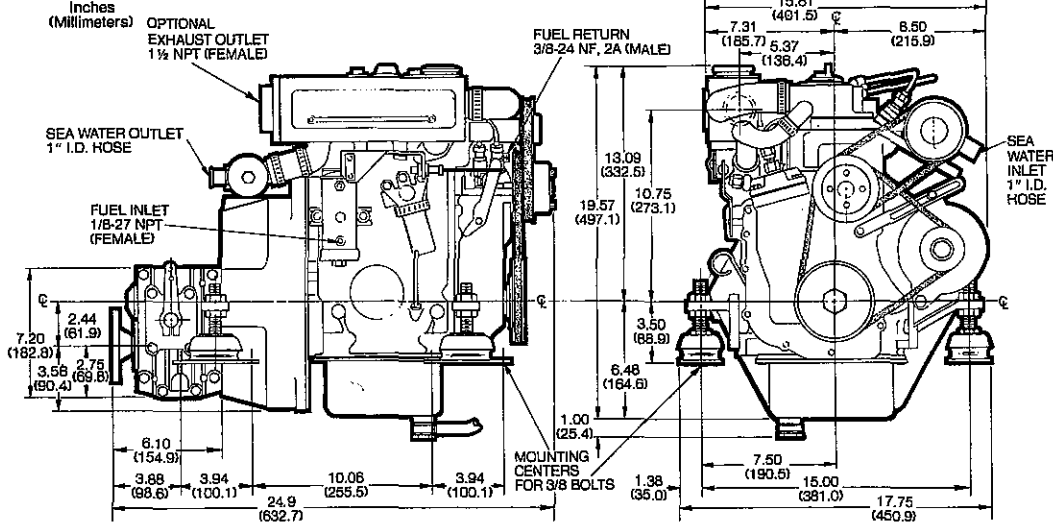

Authorized Dealer