



# Installation Manual Volvo Penta - Engine



## **Welcome Aboard**

Polar DC Generators and Volvo Penta marine engines are used all over the world today. They are used in all possible operating conditions for professional as well as leisure purposes.

Polar DC Marine is becoming a symbol of reliability, technical innovation, performance and long service life. We also believe that this is what you demand and expect of your Polar DC Marine generator.

Please read this operator's manual thoroughly and consider the advice we provide on operation and maintenance before you cast off on your voyage so that you will be ensured of fulfilling your expectations.

---

# Installation

## Marine Diesel Engines D1-13, D1-20, D1-30 D2-40, D2-55, D2-75

### Contents

<b>Safety precautions</b> .....	2
<b>General information</b> .....	5
Conversion factors .....	7
<b>Special tools</b> .....	8
<b>Installation drawings</b> .....	8
<b>Engine installation</b> .....	9
Engine inclination .....	9
Flexible shaft seal .....	10
Rigid shaft seal .....	10
Fitting of reverse gear and S-drive .....	11
S-drive insulation .....	11
Rubber mounts .....	12
Propeller shaft system .....	13
Front end power take-off .....	15
Cooling system .....	19
Exhaust system .....	24
Engine room ventilation .....	26
Soundproofing .....	28
Fuel system .....	30
<b>Electrical system</b> .....	32
Connection of battery cables .....	36
<b>Controls</b> .....	38
<b>S-drive installation</b> .....	41
Preparation .....	41
Cutting and fibreglassing of engine bed .....	43
Installation of drive and engine .....	46
Fitting of the rubber seal .....	48
Installation of propeller .....	49
<b>Oil quality and filling</b> .....	50
<b>References to Service Bulletins</b> .....	52

# Engine installation

## Engine inclination

Flywheel down

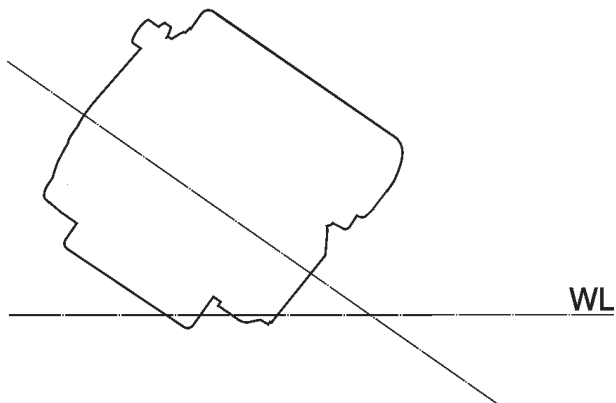

Flywheel up

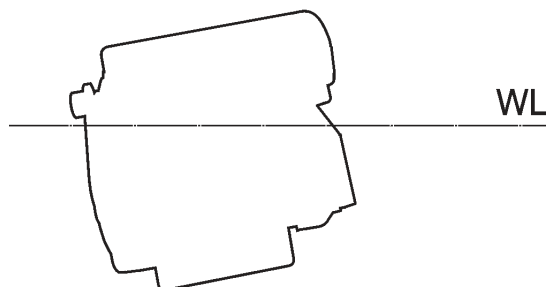

## Max. inclination

Engine	Static		Under way		
	Flywheel down	Flywheel up	down	Flywheel up	Sideways
D1-ser.	15°	0°	25°	0°	35°
D2-40	15°	0°	25°	0°	35°
D2-55/75	15°	0°	35°	10°	35°

## Service accessibility

When you design the engine installation, always pay attention to the access needed for correct engine service. Also ensure that the complete engine can be removed without damage to the boat structure.

There must also be sufficient space for the sound proofing material.

**NOTE!** See installation drawing for space required to lift out engine.

**NOTE!** Minimum recommended access two sides, front and starboard.

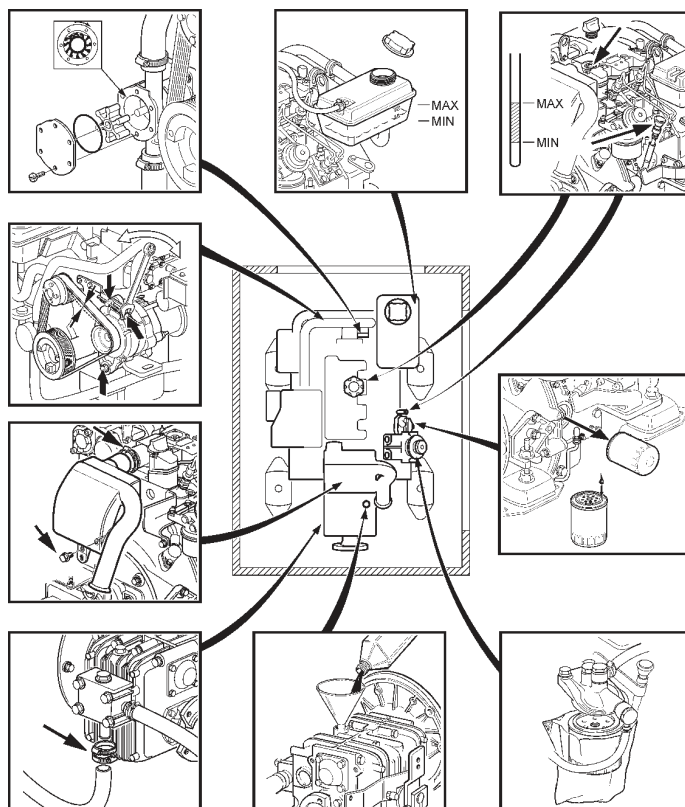

## Flexible shaft seal

Volvo 'Penta water lubricated rubber type

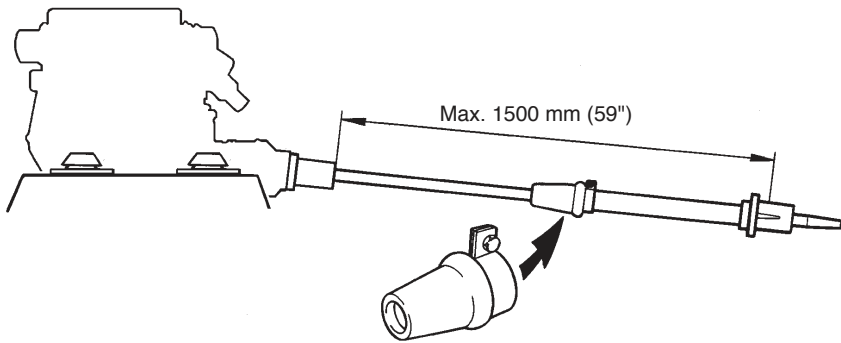

## Grease lubricated shaft seal

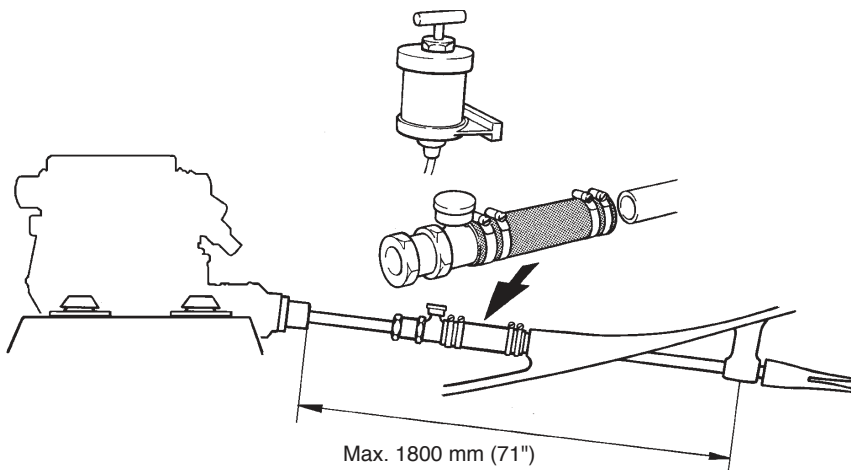

When using a flexible shaft seal and flexible engine suspension, a flexible shaft coupling must **not** be fitted.

## Rigid shaft seal

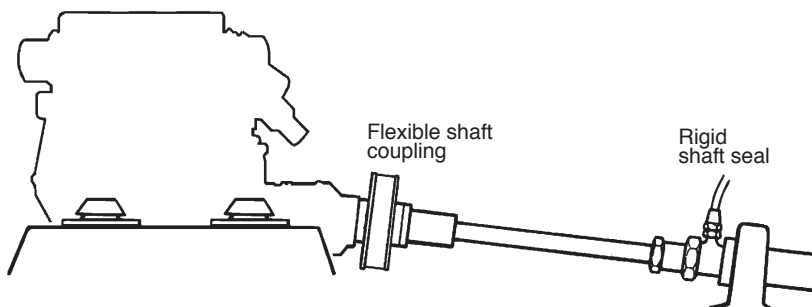

When using a rigid shaft seal and flexible engine suspension, a flexible shaft coupling must be fitted.